

RKN

CSafe RKN active temperature-controlled air cargo container



Technical specifications

Experience a higher level of performance

- Advanced active temperature-controlled container
- Superior ThermoCor® VIP insulation
- Innovative Air Recirculation System (ARS) for complete encapsulation of crucial payloads
- Efficient operational capabilities in extreme ambient temperatures (-30°C to +49°C)
- Automated data logging with free data file download

The CSafe RKN active temperature management solution was designed to protect temperature-sensitive life-science products during air cargo shipments around the world. The CSafe RKN brings an unparalleled level of precision control and temperature assurance with intelligent programming and patented VIP insulation technology. Combined with a radiant heating and compressor-driven cooling system, the CSafe RKN autonomously recirculates conditioned air throughout the cargo chamber to encapsulate the payload and provide an optimal layer of protection from temperature risks associated with long-duration shipments in extreme ambient temperature conditions. CSafe Global combines proven experience with best-in-class quality performance, and has successfully and safely transported thousands of life-enhancing shipments across the globe, commanding unmatched levels of confidence in the CSafe RKN.

Experience the CSafe RKN active temperature-management container and achieve a higher level of quality and performance.



System advantages:

- Extended battery run time of >130 hours for typical shipments
- Broad operating range maintaining payload temperature in extreme ambient temperatures (-30°C to +49°C)
- Superior passive holdover time with best-in-class insulation technology (ThermoCor® VIP)
- Readily available data logging to monitor and verify thermal integrity of payload

Performance features:

- Superior ThermoCor® VIP insulation
- Innovative ARS airflow pathway that encapsulates payload with conditioned air on all sides to ensure optimal temperature mapping and operational efficiency
- Advanced Temperature Management System (TMS) for autonomous control of innovative heating and compressor-driven cooling systems
- Array of 6 temperature sensors throughout cargo compartment for high level of redundancy in temperature and system control
- Intuitive, easy-to-use control panel to minimize user training time and effort
- User-selectable temperature set points from +4°C to +25°C, in 1°C increments
- Eliminates need for dry ice and its associated handling and Hazmat surcharges

CSafe RKN technical specifications (continued)

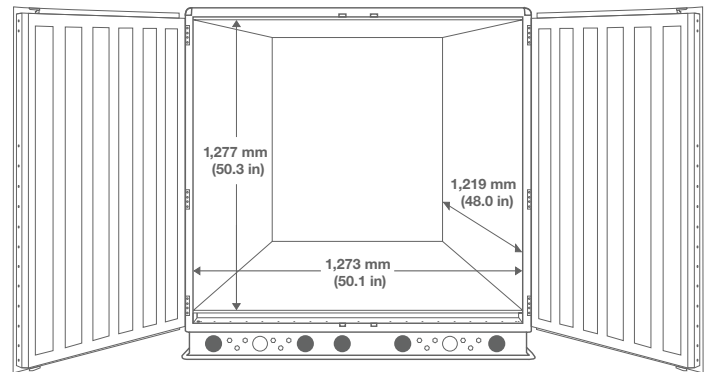
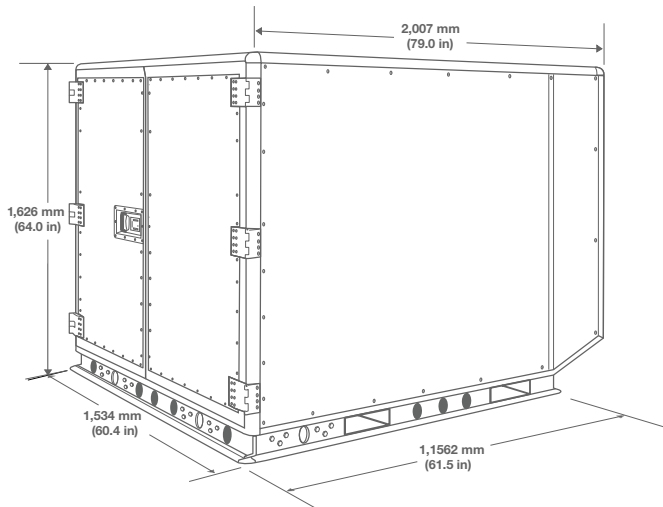

Physical specifications:

- Payload volume: 2.0 m³ (70 ft³)
- Internal dimensions (L x W x H):
1,219 mm x 1,273 mm x 1,278 mm
(48.0 in x 50.1 in x 50.3 in)
- External dimensions (L x W x H):
1,962 mm x 1,505 mm x 1,614 mm
(77.3 in x 59.3 in x 63.6 in)
- Tare weight: 646 kg (1,425 lb)
- Maximum payload weight: 941 kg (2,075 lb)
- Maximum allowable weight: 1,588 kg (3,500 lb)

Data features:

- Automated data logging of cargo compartment temperature, ambient temperature, door opening events, and battery status
- Downloadable, free data file available via integrated USB port allowing for immediate access to shipment data

Power features:

- Power sources:
 - ▶ AC power (100-240 V, 50-60 Hz)
 - ▶ Internal batteries (regulatory approved, sealed, nonspillable design that meets Dangerous Goods Regulations)
- Rechargeable anywhere in the world with included multisystem charging cables
- Rapid battery charging, from 0% to 100% in only 4 hours
- Run time >130 hours for typical shipments

Design features:

- Suitable for use on all wide-body aircraft, with regulatory approval for use on both lower and upper decks
- Forkliftable base with flat bottom for roller conveyor transport and aircraft loading
- Large cargo chamber designed to easily manage 1 standard US or Euro pallet, in any orientation
- Wide-opening door for easy access to cargo area
- Innovative ARS for complete airflow encapsulation of payload
- Superior ThermoCor® VIP Insulation to protect payload temperature in the event of catastrophic failure
- Optimized internal airflow recirculation, eliminating the need for pallet loading



Keeping temperatures precisely where they need to be

US Toll-Free: 1.888.323.9576 | International: +1.937.245.6350
Email: Sales@CSafeGlobal.com | Web: CSafeGlobal.com

CSafe, ThermoCor®, and the logo designs presented in this material are trademarks or registered trademarks of CSafe Global. © 2018 CSafe.

DSRKN072418US

