



Single-Pallet Active Temperature-Controlled Container

CSafe RKN containers protect temperature-sensitive life-science products during air cargo shipments around the world. They offer unparalleled precision and temperature assurance with intelligent programming and patented VIP insulation technology. Combined with a radiant heating and compressor-driven cooling system, the CSafe RKN autonomously recirculates conditioned air throughout the cargo chamber to encapsulate the payload and provide an optimal layer of protection from temperature risks associated with long-duration shipments in extreme ambient temperature conditions.



Key Features



Advanced Temperature Management System (TMS) for autonomous control of heating and cooling systems



Unmatched operational capabilities in extreme ambient temperatures (-30°C to +49°C)



Innovative Air Recirculation System (ARS) for complete encapsulation of payloads



Suitable for use on all widebody aircraft, with regulatory approval for use on both lower and upper decks



Forkliftable base with flat bottom for roller conveyor transport and aircraft loading



Superior VIP insulation protects payload in the event of a failure



Integrated real-time visibility tracker



Array of 6 temperature sensors throughout cargo compartment



User-selectable temperatures from +4°C through +25°C



Designed to easily manage 1 standard US or Euro pallet, in any orientation



Wide-opening door for easy access to cargo area



PAYLOAD (CUBIC METERS)
2.0



TEMPERATURE RANGE*
+2°C to +8°C
+15°C to +25°C



DURATION (HOURS)
130+

Technical Specifications

PRODUCT NAME	PAYLOAD	TEMPERATURE RANGE*	DURATION	INTERNAL SPACE L x W x H	EXTERNAL DIMENSIONS L x W x H	TARE WEIGHT	MAXIMUM PAYLOAD WEIGHT	MAXIMUM ALLOWABLE WEIGHT
CSafe RKN	2.0 m ³ 70 cu ft	+2°C to +8°C +15°C to +25°C	130+ hrs	1219 x 1273 x 1277 mm 48 x 50.1 x 50.3 in	2007 x 1534 x 1626 mm 79.0 x 60.4 x 64.0 in	646 kg 1425 lbs	941 kg 2075 lbs	1588 kg 3500 lbs

*Coming soon: - 20°C for frozen shipments

Power Features

- Power sources:
 - AC power (100-240 V, 50-60 Hz)
 - Internal batteries (regulatory approved, sealed, nonspillable design that meets Dangerous Goods Regulations)
- Rechargeable anywhere in the world with included multisystem charging cables
- Rapid battery charging, from 0% to 100% in only 4 hours
- Run time >130 hours for typical shipments

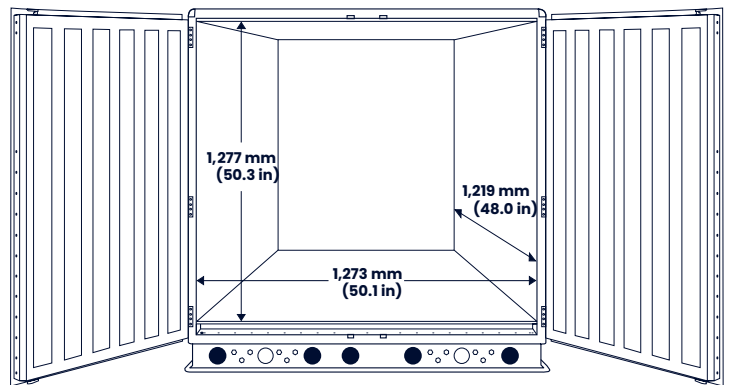
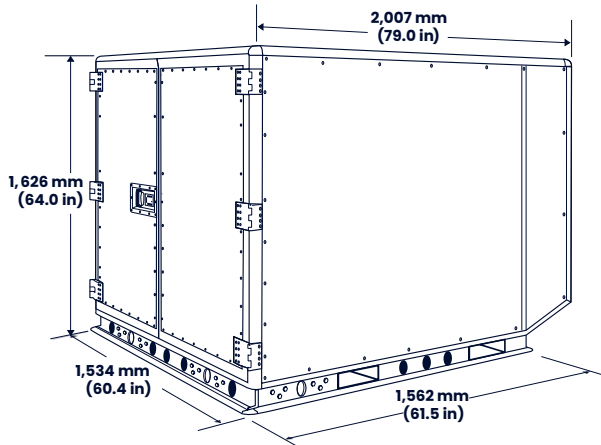

Contact us at sales@csafeglobal.com

CSafe has a global network of service centers, stations, supply points and team members to provide support and solutions where and when you need them. CSafe and the logo designs presented in this material are trademarks or registered trademarks of CSafe. ©2023 CSafe

