

Multi-Pallet Active Temperature-Controlled Container

Offering the largest payload capacity in the industry, the CSafe RAP leverages the groundbreaking heating and compressor-driven cooling technologies of the CSafe RKN with advanced VIP insulation to eliminate thermal risks to cargo traveling through extreme ambient temperature conditions on long-duration shipments.



Key Features



Advanced Temperature Management System (TMS) for autonomous control of heating and cooling systems



Unmatched operational capabilities in extreme ambient temperatures (-30°C to +54°C)



Innovative Air Recirculation System (ARS) for complete encapsulation of payloads



Suitable for use on all widebody aircraft, with regulatory approval for use on both lower and upper decks



Forkliftable base with flat bottom for roller conveyor transport and aircraft loading



Integrated real-time visibility tracker



Array of 10 temperature sensors throughout cargo compartment



User-selectable temperatures from +4°C through +25°C



Designed to easily manage 4 standard US pallets or 5 Euro pallets



Wide-opening doors for easy access to cargo area

Technical Specifications

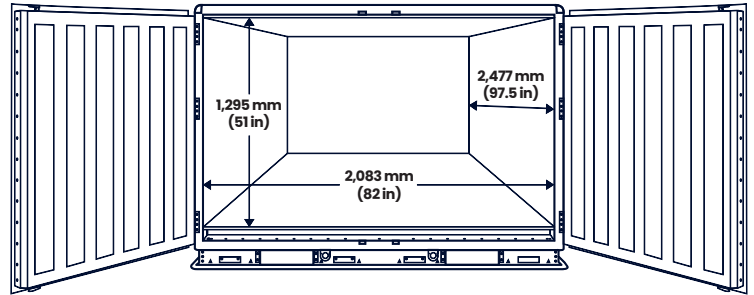
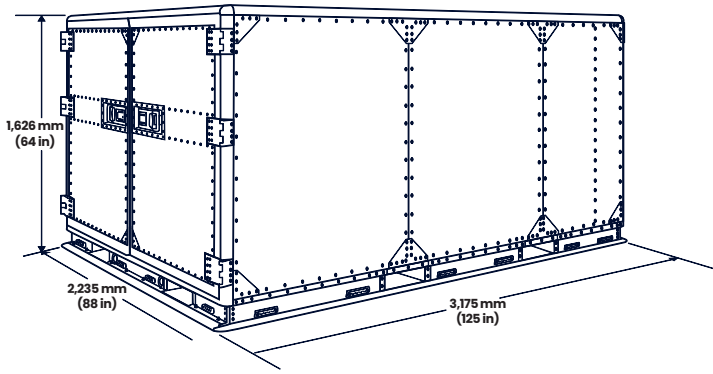

Product Name	Payload	Temperature Range	Duration	Internal Space L x W x H	External Dimensions L x W x H	Tare Weight	Maximum Payload Weight	Maximum Allowable Weight
CSafe RAP	6.68 m ³ 236 cu ft	+2°C to +8°C +15°C to +25°C	120+ hrs	2477 x 2083 x 1295 mm 97.5 x 82 x 51 in	3175 x 2235 x 1626 mm 125 x 88 x 64 in	1213 kg 2675 lbs	4819 kg 10625 lbs	6033 kg 13300 lbs



Payload (cubic meters)
6.68



Temperature range
+2°C to +8°C
+15°C to +25°C



Duration (hours)
120+

Power Features

- Power sources:
 - AC power (100-240 V, 50-60 Hz)
 - Internal batteries (regulatory approved, sealed, nonspillable design that meets Dangerous Goods Regulations)
- Rechargeable anywhere in the world with included multisystem charging cables
- Rapid battery charging, from **0% to 100%** in only **10 hours**
- Run time **>120 hours** for typical shipments

Contact us at sales@csafeglobal.com

CSafe has a global network of service centers, stations, supply points and team members to provide support and solutions where and when you need them. CSafe and the logo designs presented in this material are trademarks or registered trademarks of CSafe. ©2025 CSafe